

BERT FRANK

SPATE TABLE LAMP

MAINTENANCE

- Lacquered brass should be wiped with a soft duster.
- Opal glass should be gently cleaned with a suitable glass cleaner and a clean, lint free cloth.
- Do not clean with any other liquid, chemical or abrasive cleaners.
- All electrical work must be conducted by a qualified electrician.

TECHNICAL

- 2x LED ribbon 24V 2700K
- 1x LED Plug In Driver - 24V Constant Voltage

www.berfrank.co.uk
+44 (0)207 164 6482

INSTRUCTION

- 1
- Position table lamp on a stable, flat surface.
 - To fit glass shade, remove 3x marble orbs and rods, 2x screws and brass plate from top of fixture.

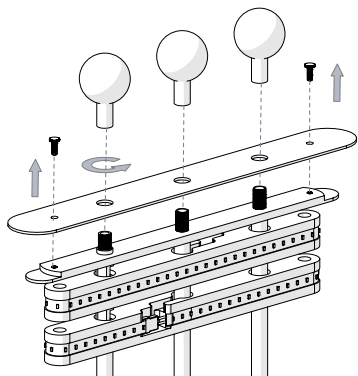

- 2
- Carefully lower glass shade over assembly until it aligns and rests around aluminium mounting plate.

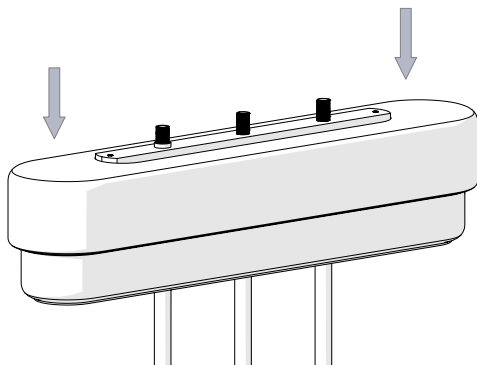

- 3
- Replace brass plate, 2x screws and 3x marble orbs and rods to top of fixture, gently tightening against glass shade.

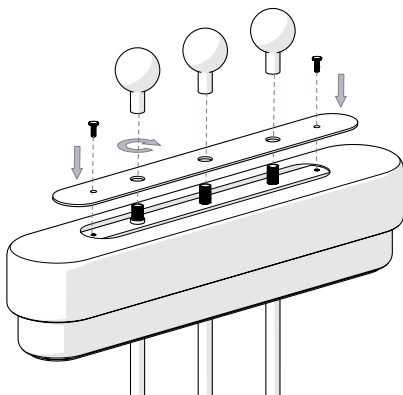

4

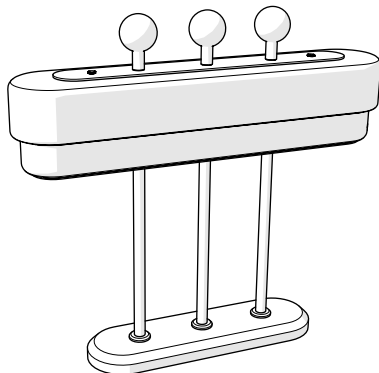

LED REPLACEMENT INSTRUCTION

- 1 - Remove 2x screws, 3x marble orbs and rods and brass plate from top of fixture.

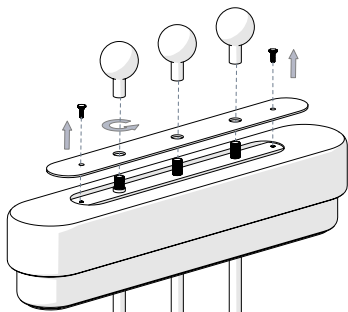

- 2 - Carefully raise glass shade and remove.

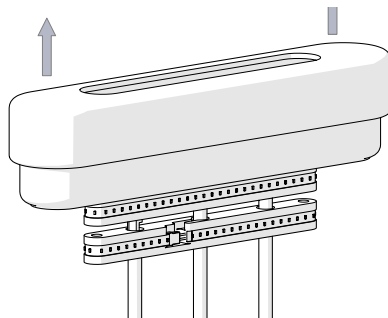

- 3 - Disconnect electrical connectors and remove unwanted LED tape by carefully peeling off aluminium mounting block.

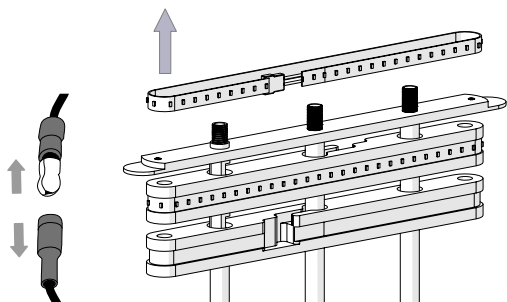

- 4 - Connect new LED tape using electrical connectors. Starting at connection end, peel back adhesive strip and lay LED tape inside groove on aluminium mounting block. Keeping it straight and flat, lay until ends meet.

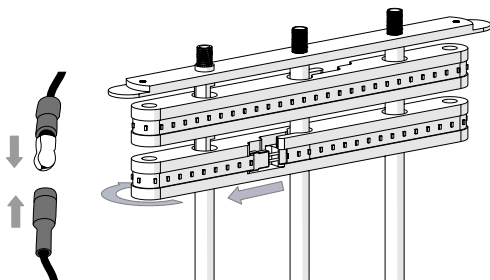

- 5 - Carefully replace glass shade over assembly until it aligns and rests around aluminium mounting plate.

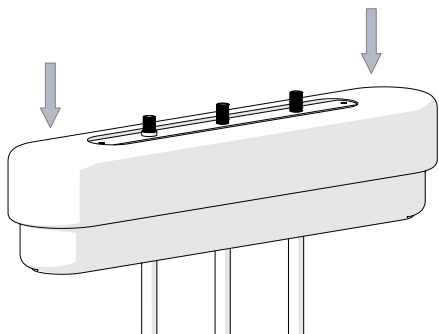

- 6 - Replace 2x screws, 3x marble orbs and rods and brass plate to top of fixture, gently tightening against glass shade.

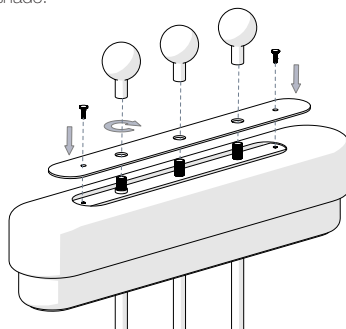

This product is only suitable for connection to the native power supply to which the unit was specifically manufactured. It is for indoor use only, and not suitable for a bathroom location.

If the Class II, double insulated symbol is on the lamp, it does not require an Earth, and Live or Neutral must not be connected to Earth. If there is no such symbol, then the lamp must be Earthed.

Under no circumstances must this lamp be covered with any material as this could pose a safety hazard. It must be used on a stable, flat surface.

Do not connect this lamp directly to mains power. If the mains cable becomes damaged it must only be replaced by a technically competent, qualified person.

Allow 10 minutes to cool before replacing, adjusting or cleaning. Do not use unspecified liquid, chemical or abrasive cleaners on this product.

If you are in any doubt about your competence please consult a qualified electrician. If any modification is made it will invalidate the warranty and may render the product unsafe.